

효과적인 워터마크 신호의 생성과 보호 및 터보코딩을 이용한 전송채널상에서의 화질 보존

조 동 옥[†] · 배 영 래^{††}

요 약

본 논문에서는 워터마킹과 채널코딩을 통한 효율적인 전송단의 구현 방법에 대해 제안하고자 한다. 통상 영상 통신 시스템은 전송단과 수신단으로 구성되어 있는데 전송단에서 해결해야 할 부분은 제작된 영상에 대한 저작권 보호, 전송중 채널에서 발생할 수 있는 잡음에 대처하기 위한 코딩과 영상 압축이다. 본 논문에서는 이 중 영상에 대한 저작권 보호와 채널 전송중 발생할 잡음을 제거하기 위해 워터마크 신호와 원 영상의 신호를 동시에 보호할 수 있는 채널 코딩 방법을 제안하고자 한다. 우선 영상에 대한 저작권 보호를 행해야 하는데 이를 위해 영상의 구조파악을 행하여 영상의 화질 개선과 워터마크 신호의 생성을 동시에 행한다. 그 후 화질이 개선된 영상의 히스토그램을 생성하여 이를 워터마크 신호로 선정한다. 이때 화소의 최하위 4비트에 곡선 적합의 계수를 삽입함으로써 워터마크 신호의 은닉에 따른 화질의 저하가 발생치 않도록 하였다. 또한 영상 전송시 발생할 수 있는 잡음을 제거하기 위해 채널 코딩 방법중 가장 오류정정능력이 뛰어난 터보코딩을 적용하여 워터마크 신호의 보호와 원 영상의 화질을 보호하였으며 특별히 세미 랜덤 인터리버라고 불리는 새로운 인터리빙 방법을 제안하였다.

Generation and Protection of Efficient Watermark Signals and Image Quality Preservation in Transmission Channel Using Turbo Coding

Dong Uk Cho[†] · Younglae Bae^{††}

ABSTRACT

In this paper, an implementation method of the efficient image transmission stage using watermarking and channel coding is proposed. Usually, image communication system consists of both a transmitter part and a receiver part. The transmitter part takes charge of copyright protection of the generated image data, and image coding and compression that can deal with channel noises when transmitting. In the transmitter part, we propose a channel coding method which protects both the watermark signal and the original signal for protecting the copyright of image data and solving channel noises when transmitting. Firstly, copyright protection of image data is conducted. For this, image structure analysis is performed, and both the improvement of image quality and the generation of the watermark signal are made. Then, the histogram is constructed and the watermark signals are selected from this. At this stage, by embedding of the coefficients of curve fitness into the lower 4 bits of the image data pixels, image quality degradation due to the embedding of watermark signals are prevented. Finally, turbo coding, which has the most efficient error correction capability in error correction codes, has been conducted to protect signals of watermark and preserved original image quality against noises on the transmission channel. Particularly, a new interleaving method named "semi random interleaver" has been proposed.

키워드 : 워터마크(watermark), 채널코딩(channel coding)

1. Introduction

Multimedia services such as Internet and IMT-2000 have been integrated the voice, video and data on a single communication media. But video or image service is more important than voice and data services.

In the near future, image transmission services among the multimedia services are expected to be the main part, whereas voice and data services are reduced to supplementary parts. This shows that the importance of image transmission has been thus grown.

However, the generation of an image requires more expenses and efforts than that for voice and data. Also an image is a visual information. Image quality is therefore very important at the transmission stage.

[†] 정 회 원 : 도립충북과학기술대학교 정보통신학과 교수
^{††} 정 회 원 : 한국전자통신연구원
논문접수 : 2001년 2월 20일, 심사완료 : 2001년 11월 10일

For this, we propose a new watermarking method for copyright protection of image data. Also we suggest a new methodology which actively copes with noise problems possibly occurring on transmission channels so that the watermark signal is protected and the original image quality is preserved.

The existing watermark methods are divided into two major approaches, i.e., one is a spatial domain approaches [1-3] and the other is a transformation approaches [4-10]. But different watermark signals generation for individual multimedia contents such as session keys in key management systems is important aspect. Also protection of watermark signals and preservation of original image quality are significant topics in multimedia transmission systems. Therefore, we propose new method cope with two existing problem such as different generation of watermark signals for individual images and removal of noises in transmission channels.

For this, in this paper, the image quality is improved through image structure understanding, and the histogram analysis of the improved image provides the watermark signals which uses the coefficients of curve fitting. This method not only automatically provides each different watermark signals but also improves the image quality. Also, by using the coefficients of curve fitting, it prevents image quality degradation due to the embedding of watermark signals. Finally, turbo encoding is performed to prevent watermark signal losses due to the noises on channels when transmitting.

The final aim of this study is the construction of a whole system incorporating transmission and receiver ends for the multimedia data. In the system, this paper proposes a new methodology for the transmission stage, which effectively copes with channel noises possibly occurring when

generating and embedding the watermark signal, and transmitting channels so that both the watermark signal and the original image are protected.

Finally the effectiveness of the proposal is verified through various experiments.

2. System Configuration

The overall block diagram of the whole multimedia transmission system to be constructed is like (Fig. 1). From the (Fig. 1), the upper part represents transmission stage and the lower part shows the receiver stage. This paper deals with the generation and protection of watermark signals and Turbo encoding in transmission stage.

For this, we presents three parts as the followings.

Firstly, generation of each different watermark signals for individual images and the proposal of embedding method.

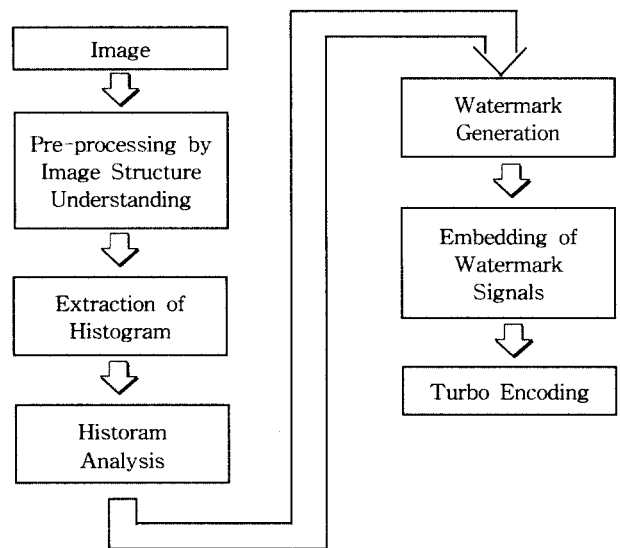

(Fig. 2) The overall Block Diagram of the Proposed Module

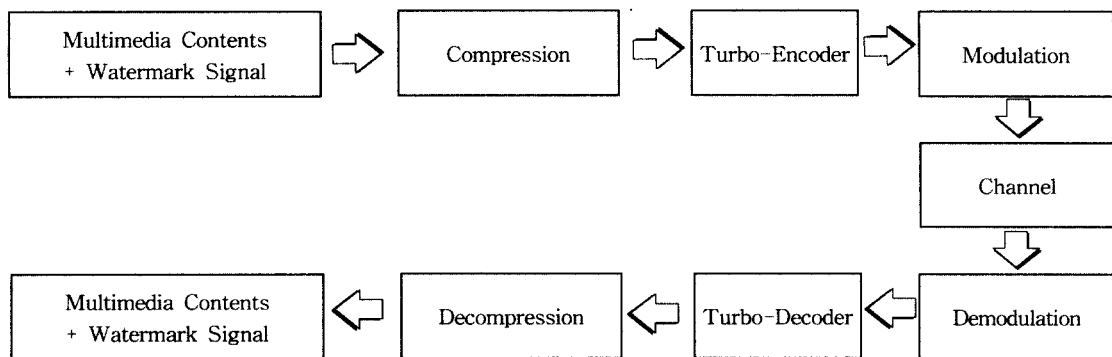

(Fig. 1) Multimedia Communications System Configuration

Secondly, generation of watermark signals while improving image qualities.

Thirdly, Turbo encoding for the protection of watermark signals and preservation of image qualities when transmitting and the proposal of new interleaver method named "semi-random interleaver."

The overall block diagram of the proposed module is like (Fig. 2)

3. Generation and Embedding of Watermark Signals

3.1 Generation of Watermark Signals

Different watermark signals for individual images such as session keys in key management system is important. For this, we propose the method which is to generate the different watermark signals for individual images. To generate the different watermark signals, we produce the histogram by the analysis of image structures distribution. And then curve fitting is done from the histogram. Also the coefficients of the curve fitting as the watermark signals to preserve the image are embedded to the original images.

The image structure is defined as follows.

Firstly, we calculate the image structures from the given image.

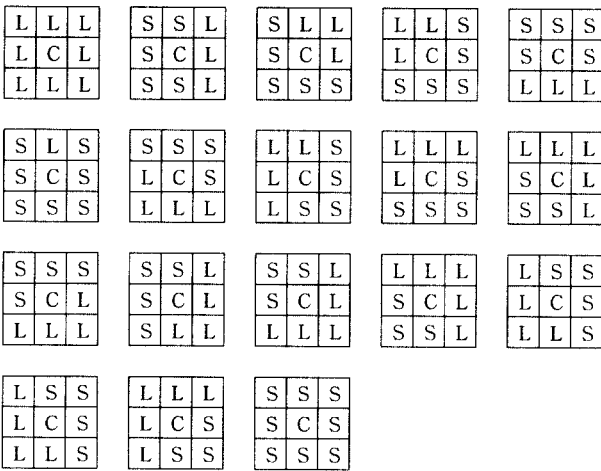

(Fig. 3) The set of image structures

The functions of 'S' and 'L' are defined as equation (1) and (2) respectively.

$$f_{Large}(X) = \frac{X}{255} \tag{1}$$

where $X = |C-L|$

$$f_{Small}(X) = \frac{-X + 255}{255} \tag{2}$$

where $X = |C-S|$

The calculation of 'S' and 'L' is accomplished from the above formula (1) and (2). For example, is the value of X is a 255 then the value of formula (1) is a '1' and the value of formula (2) is a '0'.

Therefore, the above formula (1) and (2) means the gray level difference value.

In this case, if the bright difference X, is between 0.5 and 0.6, the reduction of image entropy is operated. Finally, image quality degradation is checked after applying template matching to decide to which structure of (Fig. 3) the image belongs.

If any degradation is found, average values are applied to restore the original image, i.e, added noises on images when acquiring and pre-processing of the images are removed. The histogram of the resulted image is used to provide watermark signals. To use a histogram for watermark signals, the analysis of the histogram is performed.

Firstly, region segmentation is done. For this, the evaluation function is defined as the ratio of between-variance (V_b) to total-class variance(V_t).

Secondly, features of segmented histogram are analyzed and are selected as watermark signals. This is performed applying curve fitting of n^{th} order on each segmented region. i.e.,

$$E = \sum_{i=0}^M (y_i - P(X_i))^2 \tag{3}$$

where $P_n(X) = \sum_{k=0}^n a_k X^k$

Partial derivatives is applied for finding the coefficients of curve fitting.

$$\frac{\partial E}{\partial a_i} = \left(-2 \sum_{i=0}^M y_i X_i^i \right) + 2 \sum_{k=0}^i a_k \sum_{i=0}^M X_i^{i+k} = 0 \tag{4}$$

At this stage, we obtain the normal equation as following.

$$\sum_{k=0}^n a_k \sum_{i=0}^M X_i^{i+k} = \sum_{i=0}^M y_i X_i^i \tag{5}$$

In this paper, parabola curve fitting is adopted.

3.2 Embedding of Watermark Signals

Two pairs of three coefficients of parabola curve fitting

are embedded into the original image as watermark signals. At this stage, as all 18 signals are embedded into the lower 4 bits of image data, as integer values between 0 to 9, there does not occur any image quality degradation. Also the positions of watermark signals are selected using equation (6).

$$X_{i+1} = (aX_i + C) \text{ mod } m \quad (6)$$

where $i = 0, 1, \dots, 35$

4. Noise Removal of Channel in Transmission

To provide a highly efficient multimedia communication service, the channel coding technique capable of effective error correction has been required. For protection of watermark signals in transmitting, we applied Turbo coding technique in the several channel coder such as BCH, RS. [11-15]. We adopted the Turbo coder which has the most efficient error correction capability in the several channel coder. Turbo coding is divided into 3 stages like interleaving, turbo encoder and turbo decoder. We propose a new interleaver method called semi-random interleaver.

4.1 Semi-Random Interleaver

In this paper, a new interleaving method, the semi-random interleaver, is proposed. Let the number of input bits be N , then the size of interleaver is $N/2$. The data are sequentially written in the memory in columns.

<Table 1> Data Input Processing in Interleaver

1	2	3	4
5	6	7	8

When all the data are stored in the memory, the data are read using random number generation such as <Table 2>. Since the number of input bits is a N , the number of parenthesis in the <Table 2> is the number of random number generation. Finally, the $(N/2 + 1)^{\text{th}}$ one is put at the last position.

<Table 2> Writing Procedure in Interleaver

1(13)	2(10)	3(15)	4(14)
5(9)	6(12)	7(11)	8(16)

4.2 Turbo Encoder

Turbo coder consists of two RSC (Recursive Systematic

Convolutional Code) and an interleaver.

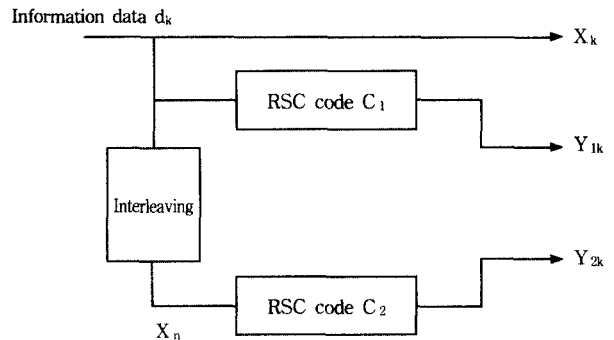

(Fig. 4) Typical Turbo Encoder

In the above figure, let the code rate be $1/2$, the length of constrained length be K , and the k -th coder input of convolutional coder be d_k bit. Then the output (X_k, Y_k) can be given as :

$$X_k = \sum_{i=0}^u g_{1i} d_{k-i} \quad d_{1i} = 0, 1 \quad (7)$$

$$Y_k = \sum_{i=0}^u g_{2i} d_{k-i} \quad d_{2i} = 0, 1 \quad (8)$$

Here, $G_1 : \{g_{1i}\}$, $G_2 : \{g_{2i}\}$ are the generation sequence, which are presented in octal digits. The constituent code of turbo coder is selected considering the transmission rate and error correction capability.

Two RSC codes are regarded as a feedback form from the feedback of convolutional code system : (Fig. 5) is a practical example and other various forms can also be configured. The structure of RSC code has an important role affecting the overall performance of turbo code coder, and so do the various constituent codes.

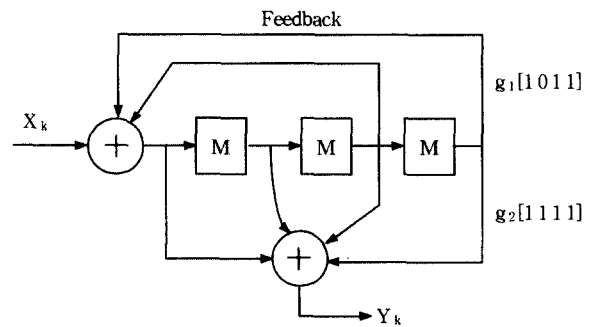

(Fig. 5) RSC Coder

The encoding process is like follows :

K th information bit d_k is directly transmitted to the output via the channel, and simultaneously is put into the first

RSC coder, which produces the output Y_{1k} .

And the output is interleaved by the interleaver between two RSC coders, which is fed into the second RSC coder producing the output Y_{2k} , which is transmitted to the next communication block.

4.3 Turbo Decoder

To decode the output code from two RSC codes, the decoder in the decoder part consists of two serially connected decoders, DEC1 and DEC2.

DEC1 decodes the information bit d_k and the first RSC coder's output, Y_{1k} . The decoded signal by DEC1 is put through the interleaver, and, with the second RSC's output Y_{2k} , is fed into DEC2. The decoded signal by DEC2 is put through the inverse interleaver, and is feedbacked to DEC1, and performs the recursive decoding to improve the performance.

The algorithm used in DEC1 and DEC2 is briefly described as follows :

The information bit is transmitted via the channel as frames of size N . Decoding is performed using MAP algorithm : MAP is an algorithm which observes the all received signal frames and choose the value which has the bigger probability, to be either 0 or 1, at any visual point.

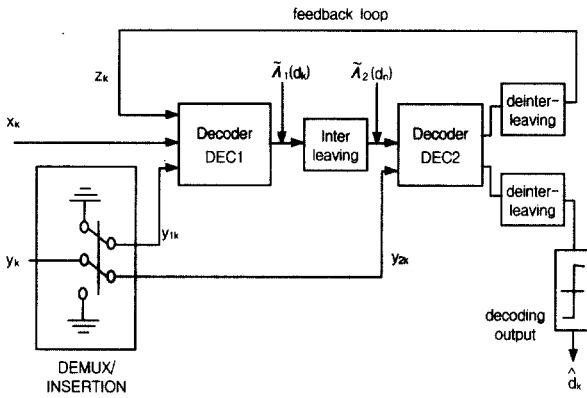

(Fig. 6) Turbo Decoder

i.e., LLR (Logarithm of Likelihood Ratio) is calculated as follows :

$$\Lambda(d_k) = \log \frac{\Pr \{d_k = 1 \mid \text{observation}\}}{\Pr \{d_k = 0 \mid \text{observation}\}}$$

Decoding is performed :

$$\begin{aligned} \Lambda(d_k) \geq 0 &\Rightarrow d_k = 1 \\ \Lambda(d_k) < 0 &\Rightarrow d_k = 0 \end{aligned}$$

LLR can be defined using state metrics $\alpha_k(m)$ and $\beta_k(m)$ as follows :

$$\Lambda(d_k) = \log \frac{\sum_m \alpha_k^1(m) \beta_k^1(m)}{\sum_m \alpha_k^0(m) \beta_k^0(m)}$$

Here, condition metrics $\alpha_k(m)$ and $\beta_k(m)$ is calculated recursively :

$$\alpha_k(m) = \delta_i(R_k, m) \sum_{j=0}^1 (S_b^j(m))$$

Where $\delta_i(R_k, m) = \Pr(R_k \mid d_k = i, S_k = m)/2$ is branch metric, which is affected from the situation of transmission channel. And it is calculated from the transmission rates of both the coder and the channel. The branch metric under AWGN channel is :

$$\delta_i(R_k, m) = \exp\left(-\frac{2}{\sigma^2} (x_k i + y_k Y_k^i(m))\right)$$

Here $S_b^j(m)$ is the reverse state induced to the state m when the input bit is i .

$Y_k^i(m)$ is a output when $S_k(m)d_k = i$ (Fig. 7) presents the matrix diagram

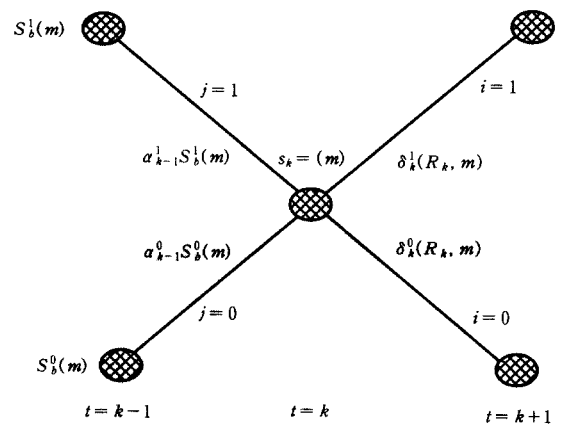

(Fig. 7) Lattice of Forward State Metric

Secondly, $\beta_k(m)$ is the following

$$\beta_k(m) = \sum_{j=0}^1 \beta_{k+1}^j(S_f^j(m)) \delta_j(R_{k+1}, S_f^j(m))$$

Where $S_f^j(m)$ is the forward state when the input bit is i .

(Fig. 8) is the lattice of this

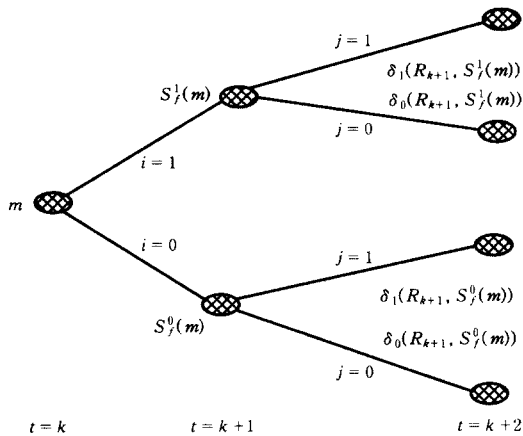

(Fig. 8) Lattice of Reverse State Metric

5. Experiments and Observations

The experiments in this paper have been performed on a Pentium CPU based PC using Visual Basic. (Fig. 9), (Fig. 10) and (Fig. 11) show the original image, quality improved image and the histogram respectively. Finally, watermark embedded image is shown in (Fig. 12). Also (Fig. 13), (Fig. 14) and (Fig. 15) show the original image, quality improved image and the histogram. (Fig. 16) is the watermark embedded image. Also semi-random interleaver for Turbo coding is experimented and the performance test results are given in <Table 3>. As shown in the experimental results, each different watermark signal is generated for individual images, which is then embedded into the original images without image quality degradation. Also semi-random interleaver has been proved to be applicable to real time image communication.

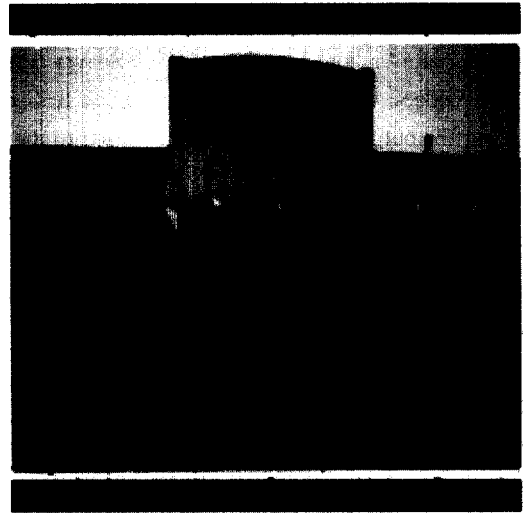

(Fig. 10) Quality Improved Image

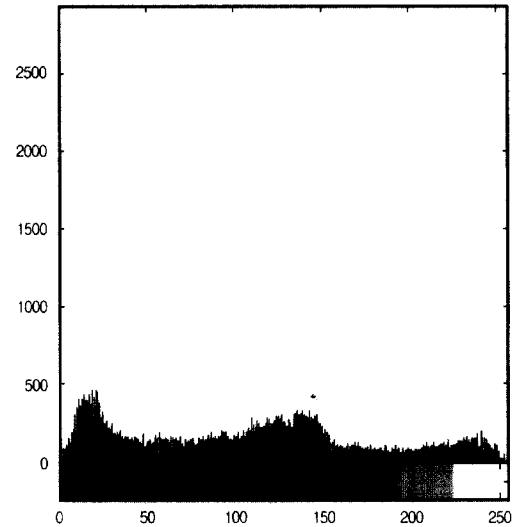

(Fig. 11) Histogram

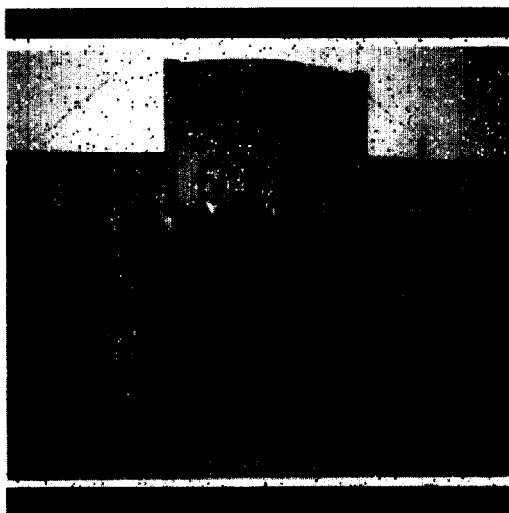

(Fig. 9) Original Image

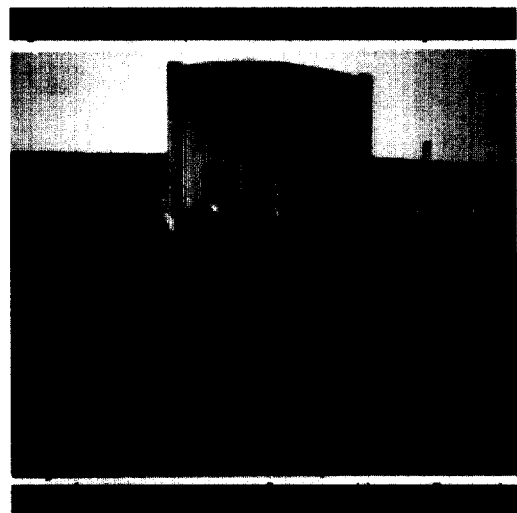

(Fig. 12) Watermark Embedded Image



(Fig. 13) Original Image



(Fig. 16) Watermark Embedded Image



(Fig. 14) Quality Improved Image

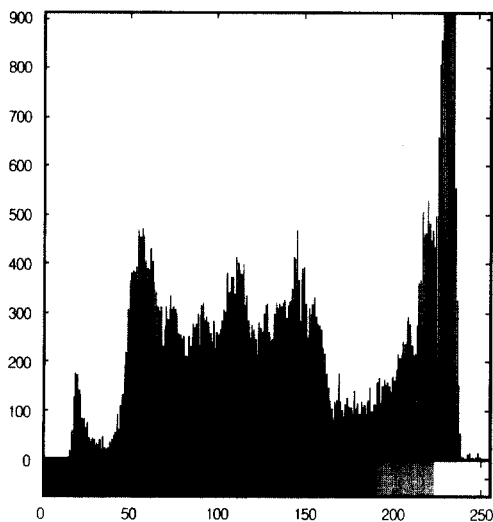

(Fig. 15) Histogram

<Table 3> Performance Evaluation Analysis of Interleaver Methods

Length of Interleaver	No. of Repetation	BER	Interleaver Methods	Eb/No [dB]
65536	6	10^{-4}	Random	0.96
			Diagonal	1.81
			Block	1.92
			Semi-Random	2.45

6. Conclusions

This paper proposes on the method of efficient transmission part in the whole image communication systems. For this, generation and embedding of watermark signals for copyrights and Turbo encoding for the protection of watermark signals and the preservation of original image qualities are proposed. In particular, this proposed digital watermarking method automatically provides each different watermark signals for individual images, which is not possible in the existing watermark techniques. Additionally it improves the image quality.

Future work will seek to address the issues, such as to apply turbo encoding on watermark embedded images.

References

- [1] N. Nikolaidis and I. Pitas, "Robust Image Watermarking in the Spatial Domain," *Signal Processing* 66, pp.385-403, 1998.
- [2] Sung Hwan Jung, "Comparison of the Robustness of Digital Image Watermark for Copyright Protection," *Korea Information Processing Society, National Conf., Vol.8, No.1, 2001.*

- [3] I. J. Cox and M. L. Miller, "A Review of Watermarking and the Importance of Perceptual Modeling," Proc. of SPIE Conf. on Human Vision and Electronic Imaging II, Vol. 3016, pp.92-99, Feb. 1997.
- [4] Y. Park, "Digital Watermarking Scheme Using Spread Spectrum Technique," Korea Information Processing Society, National Conf., Vol.8, No.1, 2001.
- [5] I. J. Cox et al, "Secure Spread Spectrum Watermarking for Multimedia," IEEE Trans on Image Processing, Vol.6, No.12, pp.1673-1687, Dec. 1997.
- [6] A. Piva et al, "DCT-based Watermark Recovering Without Resorting to the Uncorrupted Original image," Proceedings of ICIP '97, 1997.
- [7] X. G. Xia et al, "A Multiresolution Watermark for Digital Image," Proceedings of ICIP '97, 1997.
- [8] M. Barni et al, "A DCT-Domain System for Robust Image Watermarking," Signal Processing 66, pp.357-372, 1998.
- [9] Frédéric Deguillaume, "Robust 3D DFT Video Watermarking," Proceedings of SPIE, Vol.3657, 1999.
- [10] Gerit C. Langellar et al, "Watermarking by DCT Coefficient Removal : A Statistical Approach to Optimal Parameter Setting," Proceeding of SPIE, Vol.3657, 1999.
- [11] Berrou. C. & Glavieux. A., "Near Shannon Limit Error Coding and Decoding : Turbo Codes," Proc. ICC '93, 1993.
- [12] S. Y. Kim et al, "Analysis of Hardware Implementation Trend for Turbo Codes," Journal of ETRI, Vol.15, No.4, Aug. 2000.
- [13] E. Jacobsen, The EF Data Turbo Codec Prototype, EF Data Corp., May, 1999.
- [14] A. S. Barnulescu and S. S. Pietrobon, "Interleaver Design for Turbo Codes," Electronics Letters, 8th, Dec. Vol.30, No. 25, 1994.
- [15] Small World Communications, "MAPO4T Very High Speed MAP Decoder," Ver 2.0, 13 Mar. 2000, [http : //www.sworld.com.au/Products](http://www.sworld.com.au/Products).



조 동 욱

e-mail : ducho@ctech.ac.kr

He received the B.Sc degree, M.Sc degree and Ph.D degree in electronic engineering from Hanyang University, Seoul, Korea. From 1989 to 1991 he was a assistant professor of Dongyang Technical College, Seoul.

Also from 1991 to 2000 he was a associate professor of Seowon University, Chongju. Since 2000 he has been with Chungbuk Provincial Univ. of Science and Technology, where he is currently a professor of information and communications engineering. At 1999, he was a visiting professor of Oregon State University, U.S.A. He received the Academic Award (Korea Information Communications Society, 1996 and 1999), Excellent Paper Reward (Korea Information Processing Society, 2001). His major research include image processing, image understanding, biometrics and pattern recognition.

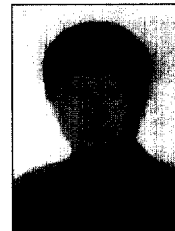

배 영 래

e-mail : yljb@etri.re.kr

He received the B.Sc degree in marine physics from Seoul National University, M. Sc degree in computer sciences from Hanyang University, Seoul, and Ph.D. degree in electronic engineering from University of Kent, England, in 1976, 1986 and 1995, respectively.

From 1976 to 1979 he was a naval officer. Since 1980 he has been with Computer & Software Technology Lab/ETRI, where he is currently the leader of the Visual Information Processing Research Team. Also he is a part time professor at Pai Chai University. As a visiting scientist, he was with the Informatik Institut, Technische Universität München, Germany, from 1988 to 1989. His major research interests include image processing, biometrics, parallel processing, and pattern recognition. He received President's Excellent Scientist Reward(1985), Excellent Paper Reward (Korea Information Processing Society, 2000). Also he is selected as Presidential Research Scientist of National Research Lab. Dr. Bae has been a regular member of the IEEE PAMI, IEEE GRSS, IEE, KITE, KISC, KSRS.